

255ml / 8oz Black Aqueous Double Wall BioCup BC-8DWB

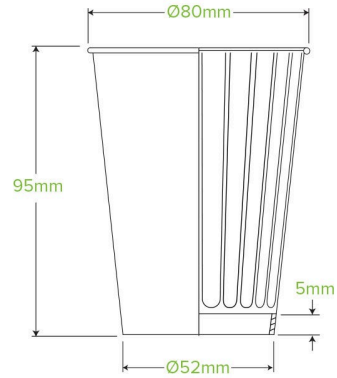

8oz Aqueous Double Wall BioCups are manufactured using a unique water-based dispersion coating certified home compostable to Australian standards (AS5810). These cups are food safe, odorless, and can be disposed of right in your backyard compost bin!

Carton quantity: 1000	Sleeves per carton: 20	Units per sleeve: 50
Carton Size LxWxH (cm): 41x33.5x60.5	Carton gross weight (kg): 12.840000	Raw Material: Paper - FSC™ Mix certified paper
Lining/coating: Aqueous	Window Material: None	Inks: Food Contact Safe Inks
Brim fill capacity (ml): 256	Dimensions top LxW (mm): 80x80	Dimensions base LxW (mm): 49x49
Product Depth: 96	Product weight (g): 13.2	Thickness: 280gsm+260gsm+8g aqueous
Use: Hot and cold	Manufactured: China	Customise: Print
MOQ custom: 50000	Mould fees: Yes - see custom packaging	Quality product certified: TBC
Factory food safety certified: BRC	Corporate social accreditation: BSCI	Home compostable: Certified to AS5810 Australian standards, Certified to NF T51-800 European standards
Industrially compostable: Certified to AS4736 Australian Standards, Certified to EN13432 European Standard	Recyclable: No	